

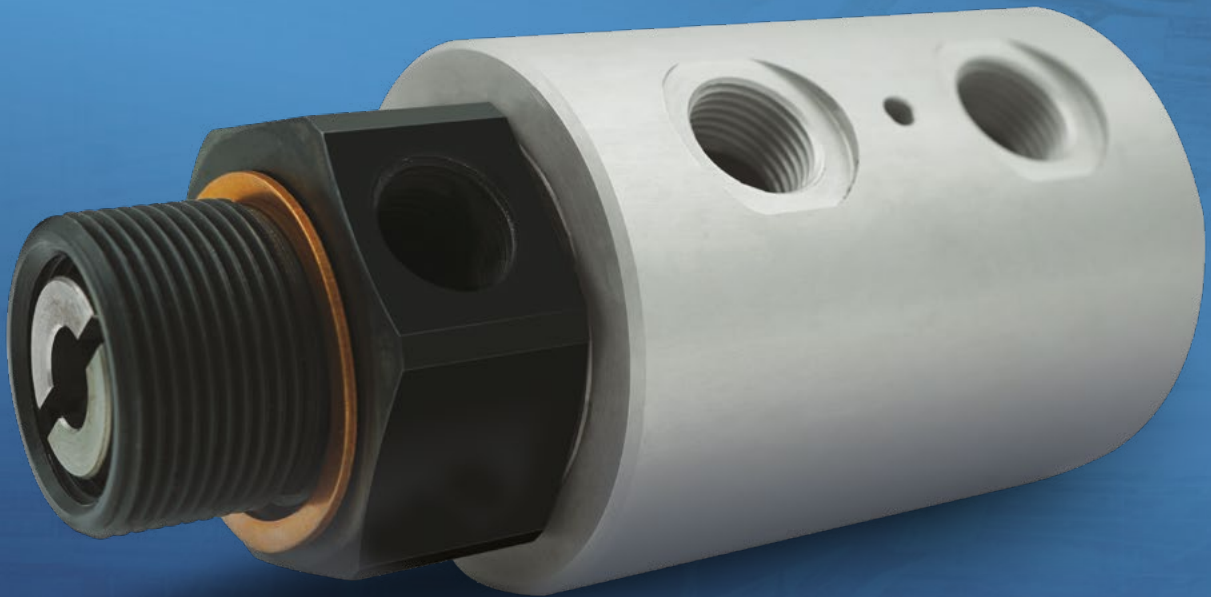

ROTARY UNIONS - GIUNTI ROTANTI

English version  |  Versione italiana



HD
series

www.girol.it/br/

HD

ROTARY JOINTS WITH TWO INDEPENDENT DIRECTIONS

Giunti rotanti con doppio passaggio indipendente

The HD Girol series is designed for the transfer of hydraulic oil and air and is mainly installed on coil unwinding reels. A special version allows water flow. It is a universal product suitable for applications requiring two independent passages; the flows are separated by high-quality sliding seals.

The joints are made of a nitrided steel rotor (with anti-corrosion treatment), an aluminum body, ball bearings, and graphite-filled PTFE seals.

The HD series is available with threaded connections or in a flanged version. Upon request, different threading standards (NPT, metric, etc.) can be manufactured.

La serie HD Girol è progettata per il passaggio di olio idraulico e aria ed è montata principalmente su aspi svolgitori per bobine. Una versione speciale consente il flusso di acqua. Si tratta di un prodotto universale che permette l'uso ovunque siano richieste due vie indipendenti; i flussi sono separati da guarnizioni striscianti di alta qualità.

I giunti sono composti da un rotore in acciaio sottoposto a nitrurazione (nitrurato con trattamento anticorrosivo), corpo in alluminio, cuscinetti a sfera e guarnizioni in PTFE caricato con grafite.

La serie HD è disponibile con attacco filettato o nella versione flangiata. Su richiesta è possibile realizzare filettature con standard differenti (NPT, metriche, ecc.).

FLUIDS

Air
Oil
Water (special version available)

ROTATION

1,000 rpm

MAX TEMPERATURE

120 °C

MAX PRESSURE

350 bar



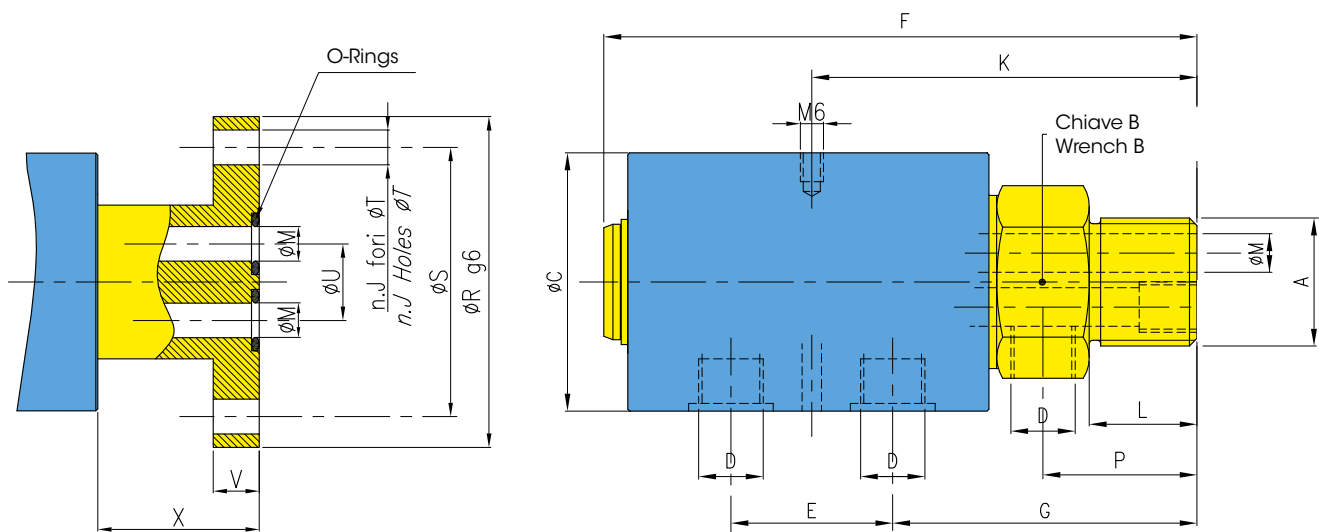

■ FIXED PARTS / Parti fisse
 ■ ROTARY PARTS / Parti rotanti

CODE codice	A	B	C	D	E	F	G	J	K
HDD025-GY6GS	3/4" BSP	50	$\frac{67}{2,637}$	1/4" BSP	$\frac{41}{1,614}$	$\frac{154}{6,062}$	$\frac{80}{3,149}$	/	$\frac{101}{3,976}$
HD0025-GY6LS	FLANGED frangiato	/	$\frac{67}{2,637}$	1/4" BSP	$\frac{41}{1,614}$	$\frac{146}{5,748}$	$\frac{73}{2,874}$	4	$\frac{93}{3,661}$
HDD037-GY6GS	1" BSP	50	$\frac{67}{2,637}$	3/8" BSP	$\frac{41}{1,614}$	$\frac{158}{6,220}$	$\frac{84}{3,307}$	/	$\frac{105}{4,133}$
HD0037-GY6LS	FLANGED frangiato	/	$\frac{67}{2,637}$	3/8" BSP	$\frac{41}{1,614}$	$\frac{146}{5,748}$	$\frac{73}{2,874}$	4	$\frac{93}{3,661}$
HDD050-GY6GS	1" 1/4 BSP	60	$\frac{79}{3,110}$	1/2" BSP	$\frac{53}{2,086}$	$\frac{178}{7,007}$	$\frac{91}{3,582}$	/	$\frac{118}{4,645}$
HD0050-GY6LS	FLANGED frangiato	/	$\frac{79}{3,110}$	1/2" BSP	$\frac{53}{2,086}$	$\frac{173}{6,811}$	$\frac{86,5}{3,405}$	4	$\frac{113}{4,448}$
HDD075-GY6GS	1" 1/2 BSP	65	$\frac{88}{3,464}$	3/4" BSP	$\frac{59}{2,322}$	$\frac{215}{8,464}$	$\frac{113}{4,448}$	/	$\frac{143}{5,629}$
HD0075-GY6LS	FLANGED frangiato	/	$\frac{108}{4,251}$	3/4" BSP	$\frac{59}{2,322}$	$\frac{233}{9,173}$	$\frac{126}{4,960}$	6	$\frac{156}{6,141}$

CODE codice	L	M	P	R(g6)	S	T	U	V
HDD025-GY6GS	$\frac{24}{0,944}$	/	$\frac{36}{1,417}$	/	/	/	/	/
HD0025-GY6LS	/	$\frac{8}{0,314}$	/	$\frac{86}{3,385}$	$\frac{70}{2,755}$	$\frac{9}{0,354}$	$\frac{20}{0,787}$	$\frac{12}{0,472}$
HDD037-GY6GS	$\frac{28}{1,102}$	/	$\frac{40}{1,574}$	/	/	/	/	/
HD0037-GY6LS	/	$\frac{10}{0,393}$	/	$\frac{86}{3,385}$	$\frac{70}{2,755}$	$\frac{9}{0,354}$	$\frac{20}{0,787}$	$\frac{12}{0,472}$
HDD050-GY6GS	$\frac{29}{1,141}$	/	$\frac{44}{1,732}$	/	/	/	/	/
HD0050-GY6LS	/	$\frac{12,5}{0,492}$	/	$\frac{108}{4,251}$	$\frac{88}{3,464}$	$\frac{11}{0,43}$	$\frac{20,5}{0,807}$	$\frac{16}{0,629}$
HDD075-GY6GS	$\frac{30}{1,181}$	/	$\frac{51}{2,007}$	/	/	/	/	/
HD0075-GY6LS	/	$\frac{19}{0,748}$	/	$\frac{148}{5,826}$	$\frac{126}{4,960}$	$\frac{13,5}{0,521}$	$\frac{33}{1,299}$	$\frac{25}{0,984}$



INSTALLATION installazione

HOW TO INSTALL // COME INSTALLARE

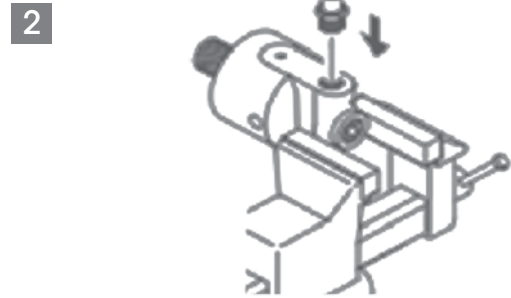
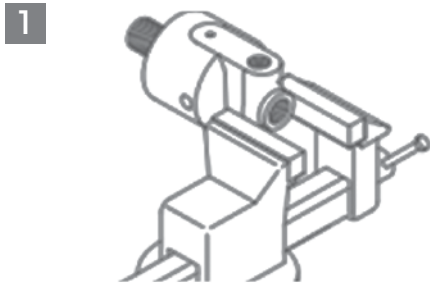

HOW TO **NOT** INSTALL // COME **NON** INSTALLARE

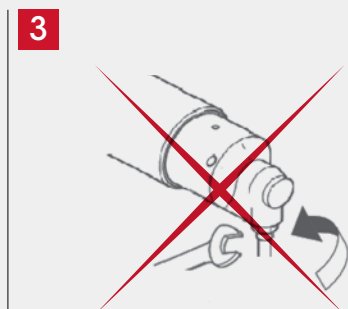
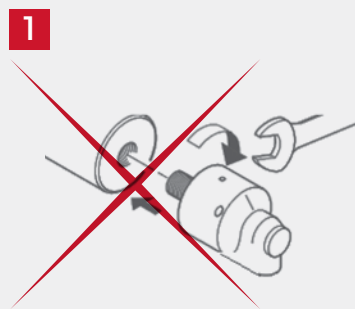

PIPES MUST BE FLEXIBLE!
ITUBI DEVONO ESSERE FLESSIBILI



HEADQUARTERS

Girol srl, via San Carlo 8, 20847 Albiate (MB), Italy
Tel: +39 0362-905204 | Fax: +39 0362-992972 | E-mail: info@girol.it
www.girol.it

RETAILERS

EUROPE

Finland

LOPITAL OY
Tel: +358 040 366 0376
info@lopital.fi

France

ROSS FRANCE (FORMERLY DIMAFLUID)
Tel: +33 1 49 45 65 65
sales@rossfrance.com

Germany

GIROL GERMANY
Tel: +49 160 500 7299
info@girol.eu

FAMAGA GROUP OHG
Tel: +49 7731 919 300
ft@famaga.de

Greece

TECNOPNEUMATIC S.A.
Tel: +30 210 347 0500
info@tecnopneumatic.gr

Hungary

MONOJET IPARTECHNIKA KFT.
Tel: +36 70 369 5393
kapcsolat@monojet.hu

Poland

INTROX SP. 200
Tel: +48 61 651 5331
tk@introx.biz

Czech Republic

KOPATECH S.R.O.
Tel: +420 797 976 543
kopatech@seznam.cz

Romania

AGMANN TECHNOLOGY S.R.L.
Tel: +40 31 229 7445
info@agmann.ro

Russia

EUROPROMPRODUCT 000
Tel: +7 343 345 6663
solid71@mail.ru

Slovenia

ALEŠ KOKOL
Tel: +386 31 568 950
a.kokol@agencija-ka.com

Spain

LIDERING S.A.
Tel: +34 934 840 4422
info@lidering.com

Switzerland

TICINO MECHANICS ENGINEERING & TRADING SAGL
Tel: +41 79 198 6477
igcp@ticinomechanics.ch

UK

INDUSTRIAL CLUTCH PARTS LTD
Tel: +44 16637 34627
sales@industrialclutch.com

Ukraine

INVEST-M ENGINEERING LTD
Tel: +38 050 500 2805
investm1@mail.ru

ASIA

China

SHANGHAI WIND CO LTD
Tel: +86 21 3990 0269
toni@ompisrl.com.cn

UAE

AL MAIMOON TRADING CO. LLC
Tel: +971 55 607 8650
agency@almaimoon.ae

India

RKB INTERNATIONAL
Tel: +91 661 250 0141
info@rkbinternational.com

Indonesia

PT. SUMITECH
Tel: +62 21 5575 5636
h.sumitaro@pt-sumitech.com

Turkey

GRT MAKİNA SANAYİ TİCARET LİMİTED ŞİRKETİ
Tel: 0552 667 66 16 - 0 543 317 99 66
ahmet.kocaturk@girolturkey.com

AMERICA

Brazil

ARTEN FREIOS & EMBREAGENS
Tel: +55 11 5594 8333
arten@arten.com

Ecuador

BEARLSA
Tel: +593 9 932 367 93
dcosta@beralsa.com

AFRICA

Morocco

AFRIC ROULEMENT
Tel: +212 522 407 010
import@africroulement.com

Open retailers
map